



# Integrated Dual-Axis Gyro

## IDG-500

### FEATURES

- Integrated X- and Y-axis gyros on a single chip
- Two separate outputs per axis for standard and high sensitivity:
  - X-/Y-Out Pins: 500°/s full scale range  
2.0mV/°/s sensitivity
  - X/Y4.5Out Pins: 110°/s full scale range  
9.1mV/°/s sensitivity
- Integrated amplifiers and low-pass filters
- Auto-Zero function
- On-chip temperature sensor
- High vibration rejection over a wide frequency range
- High cross-axis isolation by proprietary MEMS design
- 3V single-supply operation
- Hermetically sealed for temp and humidity resistance
- 10,000 g shock tolerant
- Smallest dual axis gyro package at 4 x 5 x 1.2mm
- RoHS and Green Compliant

### APPLICATIONS

- General Motion Sensing
- Vehicle Motion Analysis
- Platform Stabilization
- Inertial Measurement Units

### GENERAL DESCRIPTION

The IDG-500 is an integrated dual-axis angular rate sensor (gyroscope). It uses InvenSense's proprietary and patented MEMS technology with vertically driven, vibrating masses to make a functionally complete, low-cost, dual-axis angular rate sensor. All required electronics are integrated onto a single chip with the sensor.

The IDG-500 gyro uses two sensor elements with novel vibrating dual-mass bulk silicon configurations that sense the rate of rotation about the X- and Y-axis (in-plane sensing). This results in a unique, integrated dual-axis gyro with guaranteed-by-design vibration rejection and high cross-axis isolation. It is specifically designed for demanding consumer applications requiring low cost, small size and high performance.

The IDG-500 gyro includes the integrated electronics necessary for application-ready functionality. It incorporates X- and Y-axis low-pass filters and an EEPROM for on-chip factory calibration of the sensor. Factory trimmed scale factors eliminate the need for external active components and end-user calibration. This product is lead-free and Green Compliant.

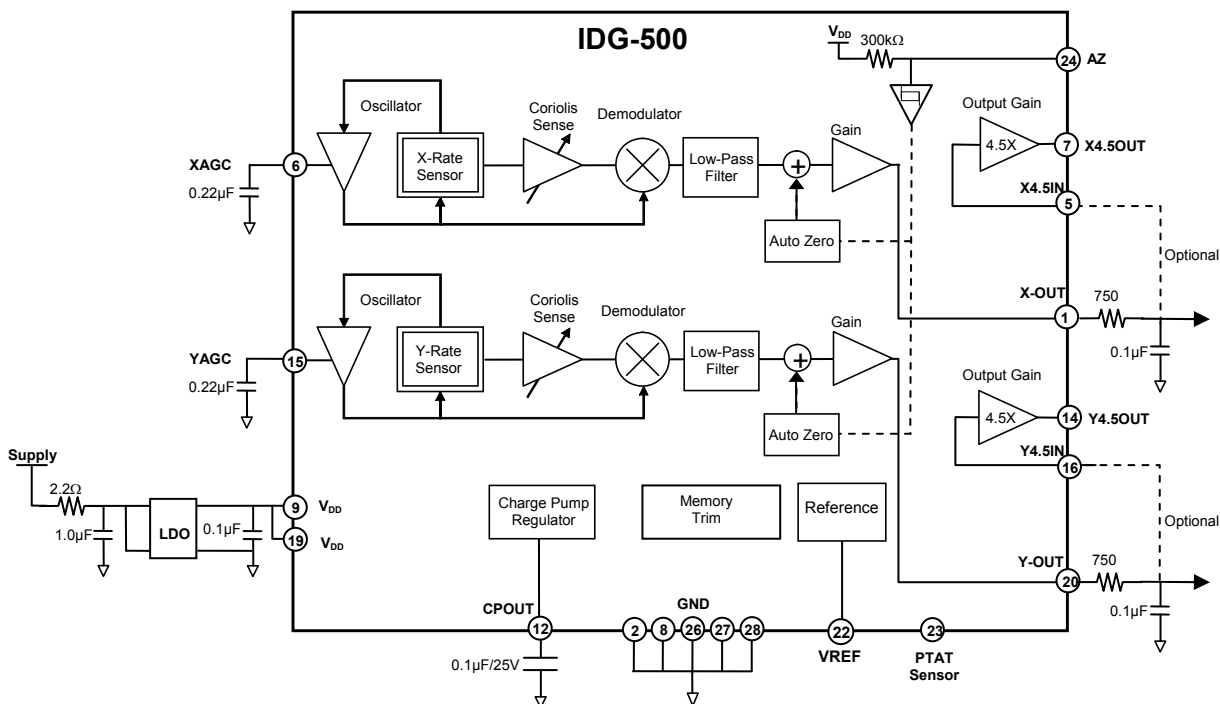



**SPECIFICATIONS**

All parameters specified are @ VDD = 3.0 V and Ta = 25°C. External LPF @ 2kHz. All specifications apply to both axes.

PARAMETER	CONDITIONS	MIN	TYP	MAX	UNITS
<b>SENSITIVITY</b>					
Full-Scale Range	At X-OUT and Y-OUT At X4.5Out and Y4.5Out		±500 ±110		°/s °/s
Sensitivity	At X-OUT and Y-OUT At X4.5Out and Y4.5Out		2.0 9.1		mV/°/s mV/°/s
Initial Calibration Tolerance	At X-OUT and Y-OUT		±6		%
Over Specified Temperature	At X-OUT and Y-OUT		±10		%
Nonlinearity	At X-OUT and Y-OUT, Best Fit Straight Line		<1		% of FS
Cross-axis Sensitivity			±1		%
<b>REFERENCE</b>					
Voltage (VREF)			1.35		V
Tolerance			±50		mV
Load Drive			100		µA
Capacitive Load Drive	Load directly connected to VREF		100		pF
Power Supply Rejection	VDD= 2.7V to 3.3V		1		mV/V
Over Specified Temperature			±5		mV
<b>ZERO-RATE OUTPUT</b>					
Static Output (Bias)	Factory Set		1.35		V
Initial Calibration Tolerance	Relative to VREF	With Auto Zero	±20		mV
		Without Auto Zero	±250		
Over Specified Temperature	Relative to VREF	Without Auto Zero	±50		mV
Power Supply Sensitivity	@ 50 Hz		10		°/sec/V
<b>FREQUENCY RESPONSE</b>					
High Frequency Cutoff	Internal LPF -90°		140		Hz
LPF Phase Delay	10Hz		-4.5		°
<b>MECHANICAL FREQUENCIES</b>					
X-Axis Resonant Frequency		20	24	28	kHz
Y-Axis Resonant Frequency		23	27	31	kHz
Frequency Separation	X and Y Gyroscopes		3		kHz
<b>NOISE PERFORMANCE</b>					
Total RMS Noise	Bandwidth 1Hz to 1kHz, At X-OUT and Y-OUT		0.8		mV rms
<b>OUTPUT DRIVE CAPABILITY</b>					
Output Voltage Swing	Load = 100kΩ to V <sub>dd</sub> /2	0.05		V <sub>dd</sub> -0.05	V
Capacitive Load Drive			100		pF
Output Impedance			100		Ω
<b>POWER ON-TIME</b>					
Zero-rate Output	Settling to ±3°/s		50	200	ms
<b>AUTO ZERO CONTROL</b>					
Auto Zero Logic High	Rising Input		1.9		V
Auto Zero Logic Low	Falling Input		0.9		V
Auto Zero Pulse Duration		2		1500	µsec
Offset Settle Time After Auto Zero			7		msec



# IDG-500

PARAMETER	CONDITIONS	MIN	TYP	MAX	UNITS
<b>POWER SUPPLY (VDD)</b> Operating Voltage Range Quiescent Supply Current Over Specified Temperature		2.7	3.0 7 ±2	3.3	V mA mA
<b>TEMPERATURE SENSOR</b> Sensitivity Offset Output Impedance	Range -20 to +85°C		4 1.25 12		mV/°C V kΩ
<b>TEMPERATURE RANGE</b> Specified Temperature Range		-20		+85	°C

## RECOMMENDED OPERATING CONDITIONS

Parameter	Min	Typical	Max	Unit
Power Supply Voltage (VDD)	2.7	3.0	3.3	V
Power Supply Voltage (VDD) Rise Time (10% - 90%)			20	ms

## ABSOLUTE MAXIMUM RATINGS

Stress above those listed as “Absolute Maximum Ratings” may cause permanent damage to the device. This is a stress rating only and functional operation of the device under these conditions is not implied. Exposure to absolute maximum rating conditions for extended periods may affect device reliability.

Parameter	Rating
Power Supply Voltage (VDD)	-0.3V to +6.0V
Acceleration (Any Axis, unpowered)	10,000g for 0.3ms
Operating Temperature Range	-40 to +105°C
Storage Temperature Range	-40 to +125°C

**PACKAGE DIMENSIONS (all dimensions in mm)**

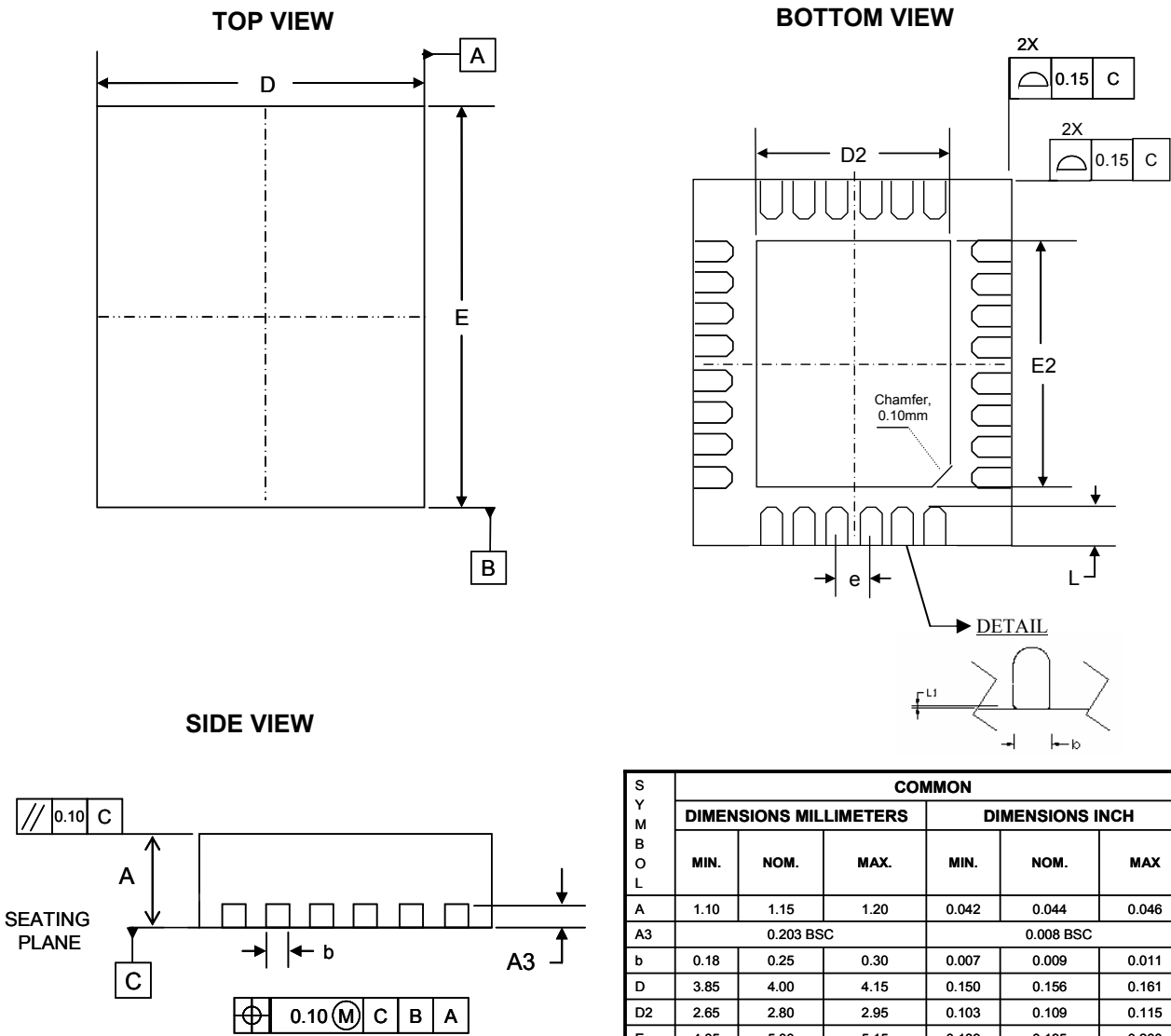

SYMBOL	COMMON					
	DIMENSIONS MILLIMETERS			DIMENSIONS INCH		
	MIN.	NOM.	MAX.	MIN.	NOM.	MAX.
A	1.10	1.15	1.20	0.042	0.044	0.046
A3	0.203 BSC			0.008 BSC		
b	0.18	0.25	0.30	0.007	0.009	0.011
D	3.85	4.00	4.15	0.150	0.156	0.161
D2	2.65	2.80	2.95	0.103	0.109	0.115
E	4.85	5.00	5.15	0.189	0.195	0.200
E2	3.50	3.65	3.80	0.137	0.142	0.148
e	0.50 BSC			0.019 BSC		
L	0.30	0.35	0.40	0.011	0.013	0.015
L1	0.00	0.08	0.15	0.000	0.003	0.006

## PIN DESCRIPTION

Number	Pin	Description
2, 8, 26, 27, 28	GND	Ground
9, 19	VDD	Positive supply voltage
1	X-OUT	Rate output for rotation about the X-axis
5	X4.5IN	X-axis input to the 4.5X amplifier
6	XAGC	Amplitude control capacitor connection
7	X4.5OUT	X-axis output of the 4.5X amplifier
12	CPOUT	Charge pump capacitor connection
14	Y4.5OUT	Y-axis output of the 4.5X amplifier
15	YAGC	Amplitude control capacitor connection
16	Y4.5IN	Y-axis input to the 4.5X amplifier
20	Y-OUT	Rate output for rotation about the Y-axis
22	VREF	Precision reference output
23	PTATS	Temperature Sensor Output
24	AZ	X & Y Auto Zero control pin
10, 11, 13, 21, 25	RESV	Reserved. Do not connect.
3, 4, 17, 18	NC	Not internally connected. May be used for PCB trace routing.

## PIN CONNECTION (TOP VIEW)

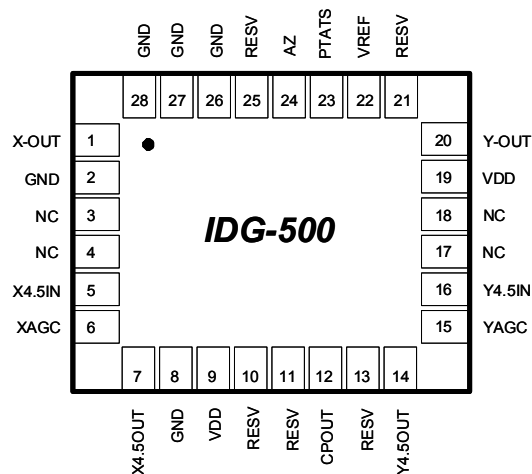

**28-pin, 4mm x 5mm x 1.2mm  
QFN Package**

## RATE SENSITIVE AXIS

This is a dual-axis rate sensing device. It produces a positive output voltage for rotation about the X- or Y-axis, as shown in the figure below.

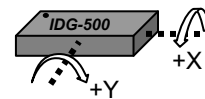

**DESIGN NOTES**
**1. Overview**

The IDG-500 gyro is a dual-axis gyroscope consisting of two independent vibratory MEMS gyroscopes. One detects rotation about the X-axis; the other detects rotation about the Y-axis. Each structure is fabricated using InvenSense's proprietary bulk silicon technology. The structures are covered and hermetically sealed at the wafer-level. The cover shields the gyro from EMI.

The gyroscope's proof-masses are electrostatically oscillated at resonance. An internal automatic gain control circuit precisely sets the oscillation of the proof masses. When the sensor is rotated about the X- or Y-axis, the Coriolis effect causes a vibration that can be detected by a capacitive pickoff. The resulting signal is amplified, demodulated, and filtered to produce an analog voltage that is proportional to the angular rate.

**2. Amplitude Control**

The scale factor of the gyroscope depends on the amplitude of the mechanical motion and the trim setting of the internal programmable gain stages. The oscillation circuit precisely controls the amplitude to maintain constant sensitivity over the temperature range. The capacitors (0.22 $\mu$ F,  $\pm$ 10%) connected to Pin 6 (XAGC) and Pin 15 (YAGC) are compensation capacitors for the amplitude control loops.

**3. Internal Low-Pass Filter**

After the demodulation stage, there is a low-pass filter that limits noise and high frequency artifacts from the demodulator before final amplification. The typical filter characteristics are shown below.

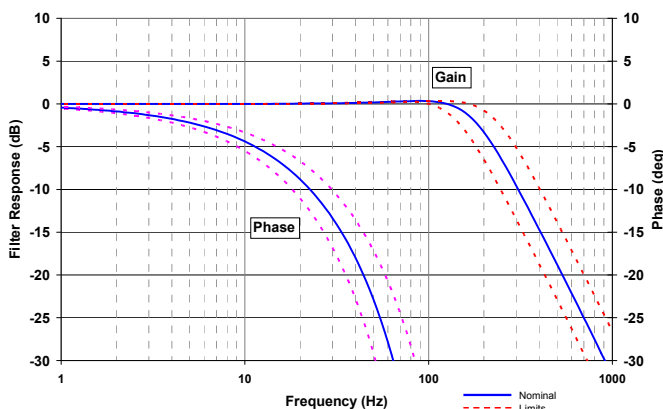
**4. External Low-Pass Filter**

To further attenuate high-frequency noise, an optional external low-pass filter may be used.

**5. Gyro Outputs**

The IDG-500 gyro has two X-outputs and two Y-outputs, with scale factors and full-scale sensitivities as summarized below.

Axis	Gyro Output	Sensitivity (mV/°/s)	Full-Scale Range ( $\pm$ °/s)
X	X-OUT	2	500
	X4.5OUT	9.1	110
Y	Y-OUT	2	500
	Y4.5OUT	9.1	100

Having two sensitivities and two full-scale ranges per output allows the end user to have one output that can be used for faster motions (over a full scale range of  $\pm$ 500°/sec), and second output that can be used for slower motions (over a full scale range of  $\pm$ 110°/sec). Thus a lower-resolution analog-to-digital converter (ADC) may be used to digitize the motion, with the gain of 4.5 in the `_4.5OUT` output effectively giving the user additional two-plus bits of resolution.

The IDG-500 gyro outputs are independent of supply voltage (i.e. they are not ratiometric).

Gyro rotation rate is calculated as:

$$\frac{(\text{Gyro Output Voltage} - \text{Gyro Zero-Rate Out})}{\text{Sensitivity}}$$

where the Zero-Rate Output (ZRO) is nominally VREF. There is a temperature dependence to ZRO, and an initial accuracy to ZRO.

**6. Auto Zero**

Auto Zero (AZ) is a function that is used to maximize the gyro's dynamic range when using the `_4.5OUT` outputs.

AZ works by keeping the gyro's Zero-Rate Output (ZRO) close to VREF, and thus allows the user to achieve a wider usable signal range, without using external analog high pass filters.

When activated, the Auto Zero circuit internally nulls the ZRO to VREF. The typical usage of Auto Zero is in conditions where:

1. The gyro's motion is known, such as when:
  - a. The gyro is stationary

- b. Other sensors can report angular rotation rate
2. The DC value of the gyro output is not important, but only the AC value is. In this case, a digital ac filter may be used to extract the gyro data, which provides a higher-quality output than is possible with an analog R-C filter.

The Auto Zero function is initiated on the rising edge of the AZ pin. The Auto Zero settling time is typically 7ms. This time includes the time required for nulling the ZRO and for the settling of the internal low pass filter (LPF). If the external LPF bandwidth is less than 200Hz, the Auto Zero settling time will be longer than specified.

The AZ pulse width should meet the specified minimum time requirement of 2 $\mu$ s to start the Auto Zero function, and should be shorter than the maximum specified time of 1500 $\mu$ s. The Auto Zero pulse should occur after the start-up period to cancel any initial calibration error.

## 7. Temperature Sensor

A built-in Proportional-To-Absolute-Temperature (PTAT) sensor provides temperature information on Pin 23 (PTATS). The temperature sensor output signal is analog, and has a bias of approximately 1.25V at room temperature, and increases at a rate of 4mV/ $^{\circ}$ C. The output impedance is nominally 12k $\Omega$  and is therefore not designed to drive low impedance loads. If necessary, the output can be externally buffered with a low offset-drift buffer, and optionally a low-pass filter to minimize noise.

## 8. High Impedance Nodes

XAGC (pin 6) and YAGC (pin 15) pins are high impedance (>1Mohm) nodes. Any coating, glue or epoxy on these pins or on the capacitors connected to these pins, will affect part performance and should be avoided.

## 9. Proper Interface Cleaning

Proper cleaning of PCB solder pads prior to assembly is recommended. PCB surface contaminants at XAGC (pin 6) or YAGC (pin 15) device interfaces may affect part performance.

## 10. Power Supply Filtering

**NOTE:** Power supply Voltage (VDD) rise time (10% - 90%) must be less than 20 ms, at VDD (pins 9 and 19), for proper device operation.

The IDG-500 gyro should be isolated from system power supply noise by a combination of an RC filter that attenuates high frequency noise and a Low Drop Out

Power supply regulator (LDO) that attenuates low frequency noise. The figure below shows a typical configuration.

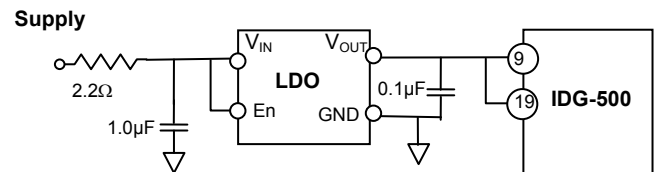

The low-pass RC filter should be chosen such that it provides significant attenuation of system noise at high frequencies. The LDO should be a low noise regulator (<100 $\mu$ V/rHz) that exhibits good noise rejection at low frequencies.



# Integrated Dual-Axis Gyro

**IDG-500**

This information furnished by InvenSense is believed to be accurate and reliable. However, no responsibility is assumed by InvenSense for its use, or for any infringements of patents or other rights of third parties that may result from its use. Specifications are subject to change without notice. InvenSense reserves the right to make changes to this product, including its circuits and software, in order to improve its design and/or performance, without prior notice. InvenSense makes no warranties, neither expressed nor implied, regarding the information and specifications contained in this document. InvenSense assumes no responsibility for any claims or damages arising from information contained in this document, or from the use of products and services detailed therein. This includes, but is not limited to, claims or damages based on the infringement of patents, copyrights, mask work and/or other intellectual property rights.

Certain intellectual property owned by InvenSense and described in this document is patent protected. No license is granted by implication or otherwise under any patent or patent rights of InvenSense. This publication supersedes and replaces all information previously supplied. Trademarks that are registered trademarks are the property of their respective companies. InvenSense sensors should not be used or sold in the development, storage, production or utilization of any conventional or mass-destructive weapons or any other weapons or life threatening applications, as well as in any other life critical applications such as medical equipment, transportation, aerospace and nuclear instruments, undersea equipment, power plant equipment, disaster prevention and crime prevention equipment.

©2008 InvenSense, Inc. All rights reserved.

